



Standard Test Method for Pullout Resistance of Ties and Anchors Embedded in Masonry Mortar Joints¹

This standard is issued under the fixed designation E754; the number immediately following the designation indicates the year of original adoption or, in the case of revision, the year of last revision. A number in parentheses indicates the year of last reapproval. A superscript epsilon (ϵ) indicates an editorial change since the last revision or reapproval.

^{ε1} NOTE—Units statement was inserted in Section 1.3 editorially in October 2014.

INTRODUCTION

The attachment of masonry walls to building exteriors has been based largely on experience and professional judgment. Codes and standards requirements relating to the attachment of masonry veneer and nonload-bearing masonry walls generally specify the size and spacing of the fasteners to be provided (ties or anchors) rather than the forces to be resisted. In addition, there are very limited data available on the structural performance of most types of fasteners currently used in masonry construction.

This test method is recommended for determining conservative ultimate pullout values of masonry fasteners under conditions that approach those usually found in the upper courses of masonry wall construction, which experience little or practically no vertical load restraint. Its use is recommended until more comprehensive methods are developed which can evaluate, economically, the capacity of masonry ties and anchors to resist pullout loads, giving due consideration to service parameters such as expanse of surrounding wall area and in-plane dead loads.

1. Scope

1.1 This test method provides procedures for determining the ability of individual masonry ties and anchors to resist extraction from a masonry mortar joint.

1.2 Two laboratory testing procedures are provided for use with test specimens which consist of a masonry tie or anchor embedded in mortar between twin stack-bonded masonry units.

1.2.1 *Procedure A*—For use with small (brick-size) masonry units.

1.2.2 *Procedure B*—For use with large (block-size) masonry units.

1.3 The values stated in inch-pound units are to be regarded as standard. The values given in parentheses are mathematical conversions to SI units that are provided for information only and are not considered standard.

1.4 *This standard does not purport to address the safety concerns, if any, associated with its use. It is the responsibility of the user of this standard to establish appropriate safety and*

health practices and determine the applicability of regulatory limitations prior to use.

2. Referenced Documents

2.1 *ASTM Standards*:²

C67 Test Methods for Sampling and Testing Brick and Structural Clay Tile

C109/C109M Test Method for Compressive Strength of Hydraulic Cement Mortars (Using 2-in. or [50-mm] Cube Specimens)

C140/C140M Test Methods for Sampling and Testing Concrete Masonry Units and Related Units

C144 Specification for Aggregate for Masonry Mortar

C270 Specification for Mortar for Unit Masonry

E4 Practices for Force Verification of Testing Machines

E6 Terminology Relating to Methods of Mechanical Testing

E171/E171M Practice for Conditioning and Testing Flexible Barrier Packaging

E575 Practice for Reporting Data from Structural Tests of Building Constructions, Elements, Connections, and Assemblies

¹ This test method is under the jurisdiction of ASTM Committee E06 on Performance of Buildings and is the direct responsibility of Subcommittee E06.13 on Structural Performance of Connections in Building Construction.

Current edition approved Oct. 1, 2014. Published October 2014. Originally approved in 1980. Last previous edition approved in 2006 as E754 – 80 (2006). DOI: 10.1520/E0754-80R14E01.

² For referenced ASTM standards, visit the ASTM website, www.astm.org, or contact ASTM Customer Service at service@astm.org. For *Annual Book of ASTM Standards* volume information, refer to the standard's Document Summary page on the ASTM website.

3. Terminology

3.1 *Definitions*—For definitions of terms used in this test method, refer to Terminology E6.

4. Summary of Test Method

4.1 These procedures provide for a static pullout test of a tie or anchor embedded in a hardened mortar joint between two masonry units.

5. Significance and Use

5.1 This test method is intended to provide a simple inexpensive means of generating conservative, comparative data on pullout strengths of various ties and anchors used with different types of masonry units and mortars. This test method is recommended for such use until economical, improved methods can be developed to simulate service conditions more inclusively.

6. Apparatus

6.1 *Procedure A (Using Brick-Size Masonry Units):*

6.1.1 The testing machine shall conform to the requirements of Practices E4.

6.1.2 Auxiliary pulling apparatus is shown in Fig. 1 and Fig. 2. These fixtures are provided with swivel joints and roller bearings to eliminate lateral restraint and bending when applying the pullout loads. The apparatus shall be designed to have enough strength and stiffness to prevent its yielding (in order to minimize apparatus deformation) and to maintain uniform distribution of the axially applied test loads until failure of the specimen occurs.

6.2 *Procedure B (Using Block-Size Masonry Units)*—Apparatus for this procedure is shown in Fig. 3 and Fig. 4. Its special purpose is to avoid handling an unwieldy specimen in apparatus such as that used in Procedure A by applying pullout loads to the specimen placed on a convenient work surface. The apparatus shall be of sufficient strength and stiffness to minimize bending deformations that would tend to promote a flexural bond failure of the mortar joint; and it shall have the capacity to develop the pullout failure load of the fastener without yielding.

6.3 For both Procedures A and B, the apparatus is made from common rolled metal sections and other stock items. The knockdown jig used for pulling the end of the fastener protruding from the masonry also serves as a reusable mold for casting a gypsum head on that end of the fastener. The mold/jig is reassembled around the gypsum pulling head when testing.

6.4 *Instrumentation*—Displacement of the fastener relative to the masonry shall be measured by a dial gage or by an electronic displacement transducer (for example, a linear variable differential transformer (LVDT)). The instrument used shall be capable of reading 0.001 in. (0.025 mm) and be accurate to 1 %.

7. Test Specimen

7.1 *Sampling of Fasteners (Masonry Ties or Anchors)*—Test at least five specimens of a given type of fastener for each given combination of masonry constituent materials. More specimens may be needed depending on the variability of the masonry constituents. If necessary, determine suitable statistical parameters to evaluate the composite variability and to

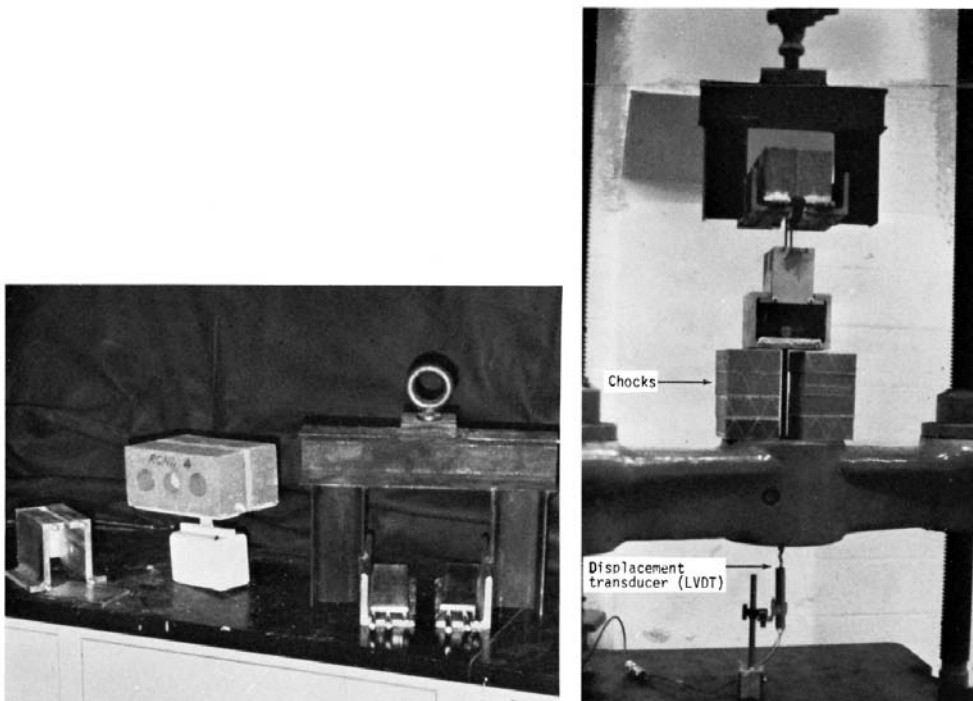

FIG. 1 Procedure A Apparatus and Setup

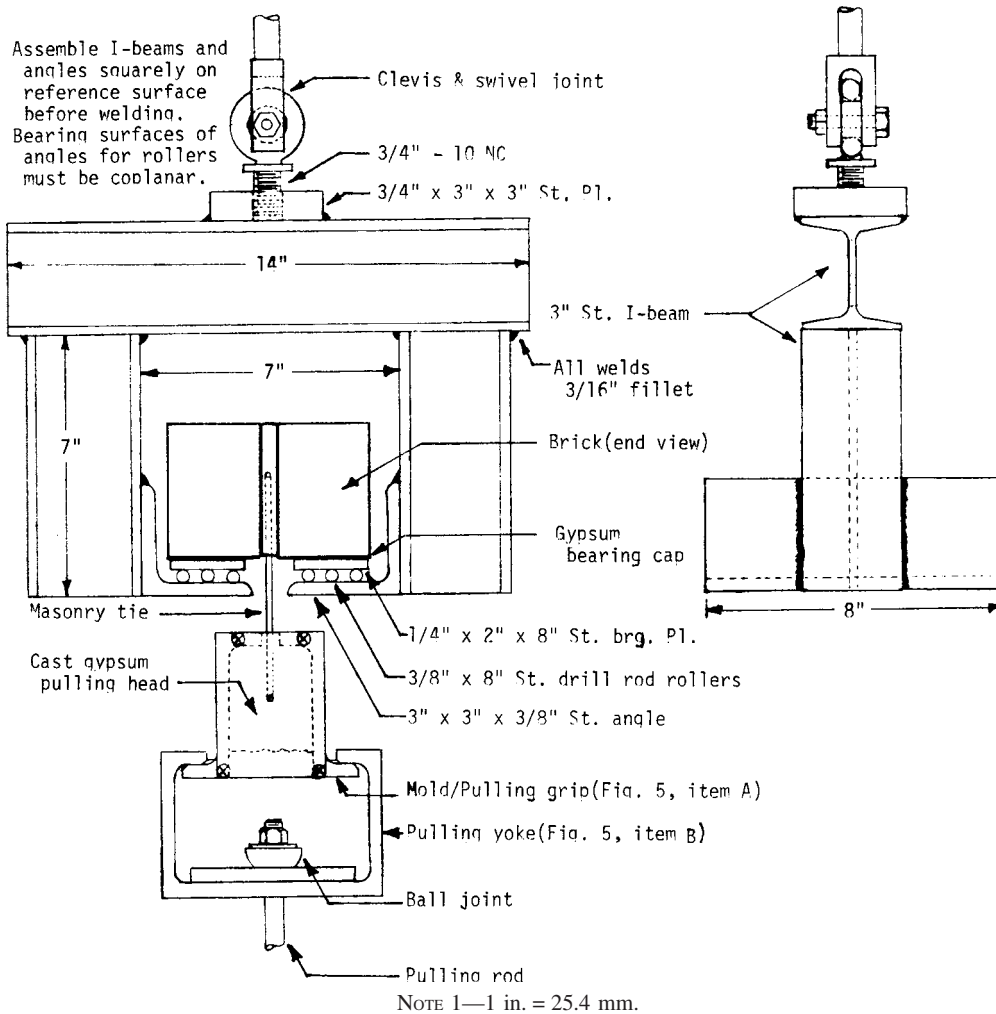

FIG. 2 Procedure A Apparatus and Setup

select the number of specimens needed for obtaining a given minimum precision in determining the capacity of the fastener.

7.2 *Sampling and Testing of Masonry Units*—Select representative masonry units and test according to applicable standard test methods (Test Methods C67 and C140/C140M) to determine basic properties.

7.3 *Sampling and Testing of Mortar*—Use mortar that is representative of that specified for the intended construction; or, for comparative research data, select one of the types of mortar specified in Specification C270. Determine the compressive strength of the mortar in accordance with Test Method C109/C109M except that the sand shall conform to Specification C144. Allow the mortar to cure undisturbed for 24 h in the molds. Release the cubes and store them in the same atmosphere as the pullout test specimens, as specified in 7.5. Determine and record the 28-day compressive strength of the mortar (at least three cubes for each set of five pullout specimens), and the sieve analysis of the sand used.

7.4 *Fabrication*—Construct at least five specimens for a given combination of variables. Make each specimen a singlewythe (one-tier), stack-bonded, two-unit prism containing one tie or anchor. Unless otherwise specified, make the single

mortar joint $\frac{3}{8}$ in. (10 mm) thick. Embed the fastener as required for its proper use at the midlength of the masonry units. (Unless otherwise specified, use a full bed of mortar on solid masonry units (without furrowing the mortar bed), and fully bed the face shells of hollow units.) Strike the mortar joint flush with the faces of the masonry units without tooling. Mark the lower masonry unit for future reference (8.4.2).

7.5 Curing and Handling:

7.5.1 Cure all pullout specimens and corresponding mortar cube specimens for 28 days. Unless other conditions are specified, cure and test all specimens in laboratory air maintained at 73°F (23°C) and 50 % relative humidity as provided by Practice E171/E171M.

7.5.2 To prevent accidental failure of mortar bond in the joints, do not disturb the pullout specimens for at least 14 days. After that time they may be handled with care in order to complete capping operations before testing at a specimen age of 28 days.

8. Procedure

8.1 *Gypsum Capping Test Specimens*—To provide a smooth bearing surface on the fastener side of the fabricated specimen,